

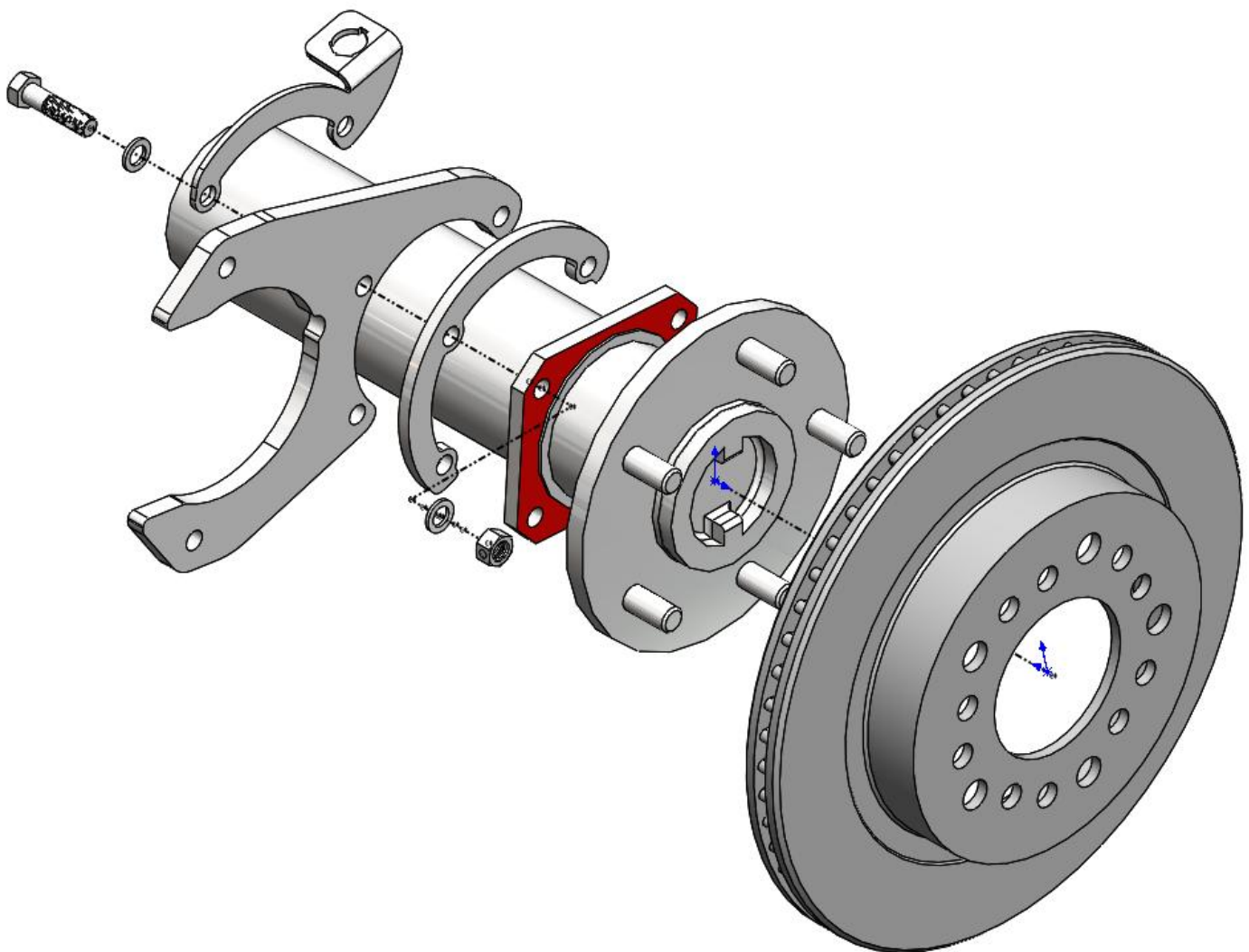

DBC-140620
GM 71-87 C10 - Rear Disc Brake Conversion



Fitment

- 71-87 Chevrolet C10 Pickup
- 71-87 GMC C15 Pickup
- 71-91 Chevrolet Blazer, Suburban, Vans
- 71-91 GMC Jimmy, Suburban, Vans

Even if your model is listed above, if it does not have the flange shown here, then the kit will not fit.

Note: The flange can be measured easily from the back side of the drum, without removing anything.

GM C10/K10

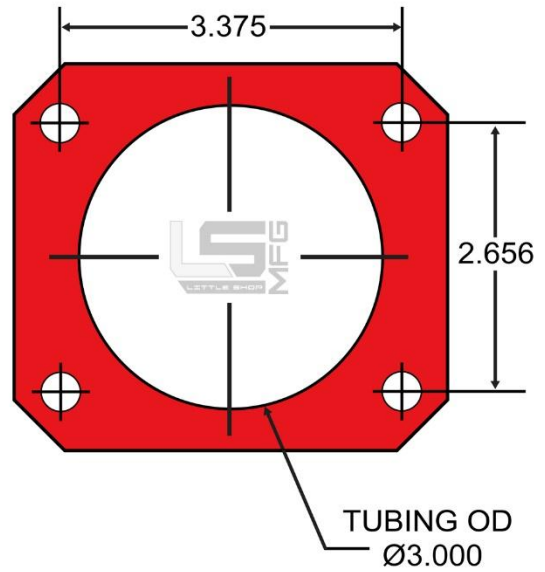

Dimensions

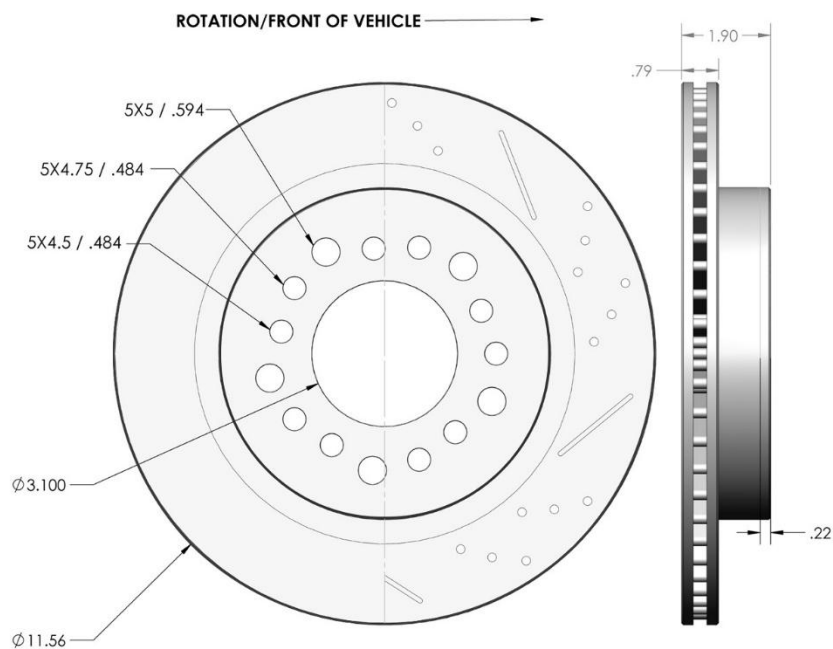

Warning

- Disc brakes should only be installed by someone experienced and competent in the installation and maintenance of disc brakes.
- If you are not sure of how to safely use this brake component or kit, you should not install or use it.
- Do not assume anything. Improperly installed or maintained brakes are dangerous. If you are not sure, get help or return the product.

Notes

- As with most suspension and tire modifications (from OEM specifications), changing the brakes may alter the front to rear brake bias. Your specific needs will depend on other modifications to the system.
- For added user control, the factory proportioning valve can be swapped to an adjustable proportioning valve such as [Wilwood 260-10922](#). Installation of a Wilwood adjustable proportioning valve will require brake line work on your end to install since it is not a direct swap.
- The brackets in this kit are designed to be installed without removing the differential cover. This can be done by use of a cut-off wheel or reciprocating saw to split the drum backing plate into two pieces for removal. If you wish to retain your drum backing plates, the axles can be removed from the housing by draining the fluid, then removing the differential cover, cross pin, and C-clip retainers.
- This kit fits most 15-inch diameter wheels and larger. If the caliper contacts the inside of a 15" wheel, in most cases it will be in limited "hot spots." It is acceptable to sand the caliper casting to create clearance in these spots so long as no more than 1/8 inch of material is removed. At the time of installation, prior to any modification, get an estimate of clearance to the wheel. If it cannot be made to work, the kit can be returned to LSMFG so long as it is in resalable condition. Shipping costs will not be included in the refund.
- If you're using 5-lug conversion axle shafts in a pre-71 2wd C10, it's important to make sure that the axle shaft flange OD is under 6.615 so that it fits the ID of our rotors. We offer 5-lug conversion axle shafts [HERE](#).
- **IMPORTANT:** If you are using a "stock replacement" axle shaft from **ANY** aftermarket company, please verify that the axle shaft flange OD, register (pilot), and wheel studs do not prevent our rotors from sitting flat against the axle shaft. It is quite common for aftermarket axle shafts to vary slightly in some way from a stock axle shaft. Another factor can be axle length versus stock, which changes axle offset. Our kits are verified to fit stock axles, with stock axle shafts. Any deviation from that configuration can cause potential issues.
- The included rotors measure .18 thickness whereas the factory drum measures .125 thick. Technically, the difference moves the wheel outboard by .055, although that amount is typically insignificant.

Notes (continued)

- **Replacement Parts:** any component in the kit is normally in stock and ready to ship from LSMFG. Refer to the [Disc Brake Parts](#) category to see most of these. If you'd like OEM fitment info on sourcing calipers, hoses, or pads from a parts store then please [CONTACT US](#). The rotors begin as an off-the-shelf part prior to being machined and zinc plated by LSMFG. This work could be copied by a competent machine shop, although it would not likely be as inexpensive as buying them as part of the kit.
- It is the responsibility of the buyer and installer of this kit to verify suitability/fitment of all components and ensure all fasteners and hardware achieve complete and proper engagement. Improper or inadequate engagement can lead to component failure.
- For any questions or suggestions, please [CONTACT US](#)

1 & 2



This installation refers to the **passenger side** of the axle. All steps are to be repeated on the driver side. Start by removing the factory drum. It may be necessary use a lubricant around the axle register to do this. Once the drum is removed, remove the brake shoe retaining springs (2 places) as shown.

3 & 4

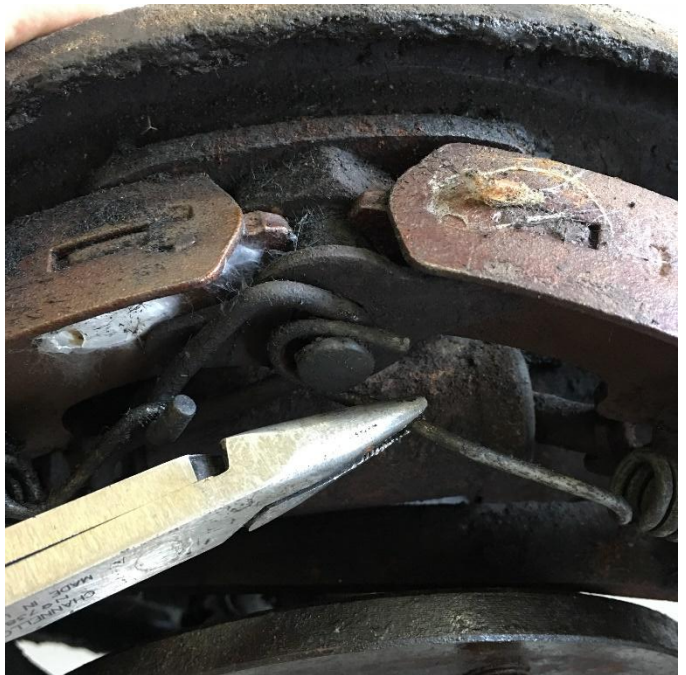

Remove the additional retaining springs from the brake shoes.



Disconnect the parking brake cable from the brake shoe, then remove and discard the brake shoes and hardware. The cable can then be removed from the backing plate by depressing its perimeter springs.

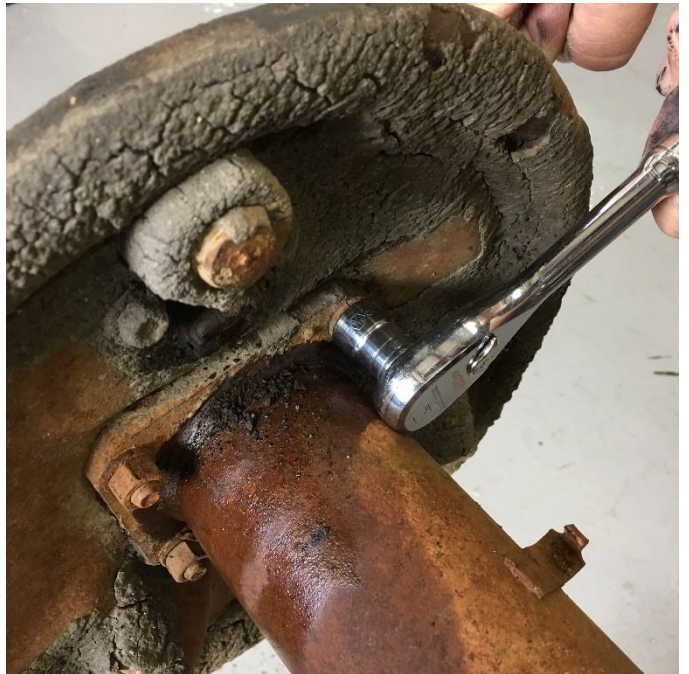

Remove the brake line from the wheel cylinder using a line wrench if possible. The 4 bolts retaining the drum backing plate to the axle can now be removed and discarded.



The brackets in this kit are designed to be installed without removing the differential cover. This can be done by use of a cut-off wheel or reciprocating saw to split the drum backing plate into two pieces for removal. If you wish to retain your drum backing plates, the axles can be removed from the housing by draining the fluid, then removing the differential cover, cross pin, and C-clip retainers.



Before installing the brackets, locate the notch as indicated. This will be mounted **UP** when the bracket is installed on the axle. Once installed, the brackets will position both calipers to the **REAR** of the axle.

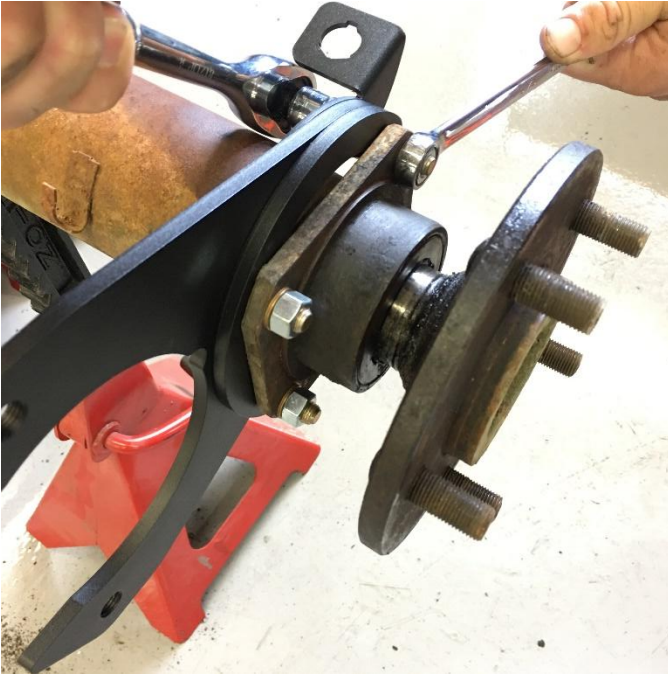

For kits with non-parking brake calipers, bolt on the brackets using the supplied hardware as shown and torque to **20ft-lbs**. Your caliper should be mounted to the **REAR** (back) of the axle. **For kits with parking brake calipers, temporarily leave these bolts loose until the caliper can be bled in the position shown under Parking Brake Caliper Setup.** The rotor can now be installed using 2 lug nuts to temporarily secure it. In the case of drilled/slotted rotors, the direction of rotation shown is for the **DRIVER SIDE**. **NOTE:** Verify that the rotors are sitting flat against the axle shaft.

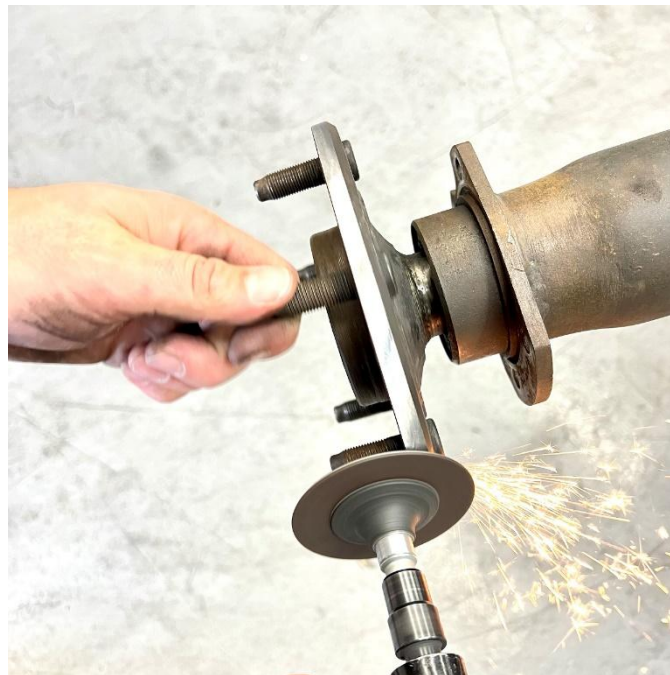

Normally not required, but in rare cases the OD of the axle shaft flange may be too large to fit inside of the supplied rotor. If this happens, the solution is to simply remove material from the outside of the axle flange with a sander while rotating the shaft as shown.



Kits with non-parking brake calipers should be checked to confirm the machined pad spacers are present and make sure the notch in the pad spacer lines up with the corresponding boss on the brake pad.

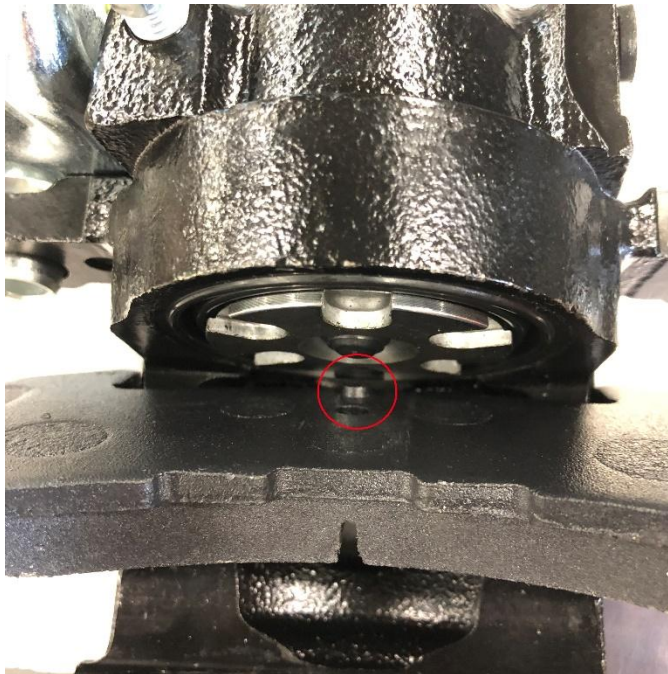

Kits with parking brake calipers do not use a machined pad spacer and should be checked to confirm the pad is seated flat against the piston face, with the boss of the brake pad lining up with the notch in the piston face.

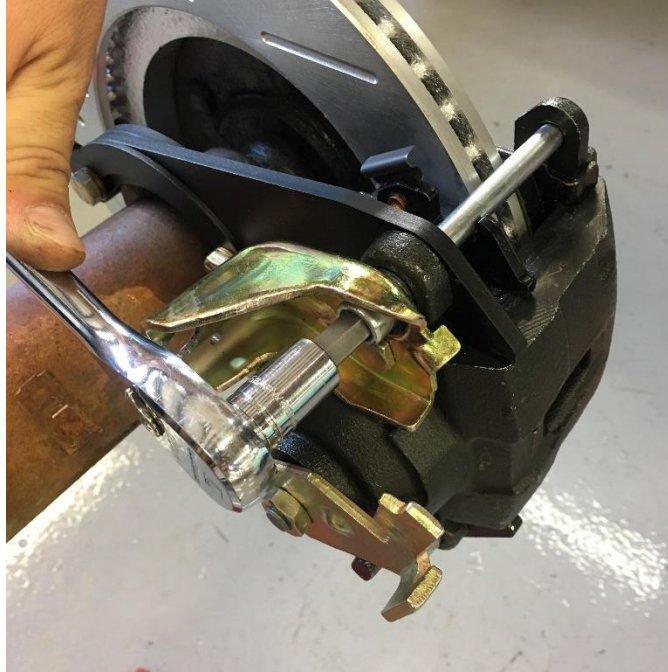

The calipers can now be installed using medium strength threadlocker (such as Loctite 243) on the two 7/16-20 caliper bolts and torque to **30 ft-lbs**. **NOTE:** If there is too much pressure on the outside pad once installed, remove the spacer between the axle flange and caliper bracket. **For parking brake calipers, refer to the instructions below for Parking Brake Caliper Setup.**

NOTE: A basic compound pad is included with the calipers in our kit (except for Wilwood calipers). Semi-metallic and ceramic pads are an option for customers who wish to minimize brake dust over time.



Install the banjo bolt and crush washers onto the hose as shown. If your hose has an offset, place the offset side of the fitting **away** from the caliper. Then install the hose onto the caliper as shown.



Install the retaining clip as shown, being careful not to bend the hose bracket. The factory brake line can then be repositioned into the top side of the brake line bracket and hose. **Use caution as to not kink the hardline during repositioning.** Next, tighten the brake line nut into your hose. It is best to use a wrench to support the rubber hose from spinning in the key of the hose bracket. **For kits without parking brake calipers, skip to Additional Information and Recommendations.**



Depending on factory cable lengths, the existing cables can sometimes be used without any modification. If they are too long, then cut off the cable stop as shown using cable cutters or a cut-off wheel. The spring can be removed with the cable installed into the parking brake caliper as shown.



The supplied cable stops can be slid over the end of the cable and against the parking brake lever. It is suggested that you tighten the set screws and adjust the system for proper function at this time. There are typically points of adjustment on the factory cables along the chassis (depending on the model and cab configuration). The cable stop itself can be moved forward or back depending on the needs of the system as well. Once it is working correctly, the excess cable can be trimmed closer to the stop. **NOTE:** Long bed trucks may require our [Parking Brake Cable Kit](#).

Parking Brake Caliper Setup and Bleeding Procedures - PLEASE READ COMPLETELY

Parking brake calipers are preadjusted so that it's not necessary to adjust them on initial installation. After the caliper is mounted the pads should be very close (within .020") to the rotor surfaces. If there is a large gap between the pads and rotor surfaces, this can cause a soft brake pedal feeling as well as poor brake performance. If the caliper does not slip over the rotor or if re-adjustment becomes necessary for another reason, refer to our [Parking Brake Adjustment Procedure](#). (This is **only** in cases where it becomes necessary and not part of a typical installation.)

We've found that traditional slow pumping of the pedal works best to bleed brake systems instead of vacuum or power bleeding, which can cause cavitation. We recommend leaving the master cylinder cap off during bleeding for that same reason.

Parking brake calipers are self-adjusting. Each time you use the parking brake, they adjust themselves for pad wear by clicking to the next stop on an internal ratchet. If you do not use your parking brake during normal operation of the vehicle, over time the pads will wear and there will be insufficient contact between the pads and the rotor. When this happens, the parking brake will never engage. Failure to adjust the parking brake can result in no parking brake, brakes dragging, overheating, premature brake wear, or ineffective rear brakes causing excessive front wear and overheating.

There are two styles of parking brake calipers, OEM bleeder type and Modified bleeder type. Identify which caliper you have and use the instructions below accordingly.

Parking Brake Caliper Bleeding for OEM Bleeder Type



When bleeding this type of parking brake caliper, it is best to temporarily position the caliper, so the screw is **horizontal to the ground**. If it is not, then it will be necessary to reposition the vehicle, the axle, or the caliper. **If the bleeder screw is not parallel to the ground while bleeding, then you can bleed gallons of fluid through it without eliminating all of the air.**

Parking Brake Caliper Bleeding for Modified Bleeder Type



When bleeding this type of parking brake caliper, it is best to temporarily position the caliper so the screw is **vertical to the ground**. If it is not, then it will be necessary to reposition the vehicle, the axle, or the caliper. **If the bleeder screw is not vertical to the ground while bleeding, then you can bleed gallons of fluid through it without eliminating all of the air.**



An easy way to accomplish this is to unbolt the main caliper bracket from the axle (leaving the caliper bolted to it) and rotate the caliper around the rotor until the bleeder screw is vertical, then perform the bleeding procedure. Keep the caliper and pads on the rotor during bleeding so that the piston doesn't over-extend outside of its bore.

Additional Information and Recommendations

- As with most suspension and tire modifications (from OEM specifications), changing the brakes may alter the front to rear brake bias. Rear brakes should not lock up before the front. Brake system evaluation and tests should be performed by persons experienced in the installation and proper operation of brake systems. Evaluation and tests should be performed under controlled conditions. Start by making several stops from low speeds then gradually work up to higher speeds. Always utilize safety restraint systems while operating the vehicle.
- To properly bleed the brake system, begin with the caliper farthest from the master cylinder. Repeat the procedure until all calipers in the system are bled, ending with the caliper closest to the master cylinder. **Note:** When using a new master cylinder, it is important to bench bleed the master cylinder first.
- Test the brake pedal. It should be firm (not spongy) and stop at least 1 inch from the floor under heavy load. If the brake pedal is spongy, bleed the system again. If the brake pedal is initially firm, but then sinks to the floor, check the system for leaks. Correct the leaks (if applicable) and then bleed the system again. If the brake pedal goes to the floor and continued bleeding of the system does not correct the problem, either air may be trapped in the system, or a master cylinder with increased capacity (larger bore diameter) may be required.

Brake Testing

- Make sure the pedal is firm: Hold firm pressure on pedal for several minutes, it should remain in position without sinking. If pedal sinks toward floor, check system for fluid leaks. **DO NOT** drive the vehicle if the pedal does not stay firm or can be pushed to the floor with normal pressure.
- At a very low speed (2-5 mph), apply the brakes hard several times while turning steering from full left to full right, repeat several times. Remove the wheels and check that components are not touching, rubbing, or leaking.
- Carefully examine all brake components, brake lines, and fittings for leaks and interference. Make sure there is no interference with wheels or suspension components.
- Drive the vehicle at a low speed (15-20 mph) making moderate and hard stops. Brakes should feel normal and positive. Again, check for leaks and interference.
- Always test vehicle in a safe place where there is no danger to (or from) other people or vehicles.
- Always wear seat belts and make use of all safety equipment.

Pad and Rotor Bedding

- Once the brake system has been tested and determined safe to operate the vehicle, follow these steps for the bedding of the pads and rotors. These procedures should only be performed on a racetrack, or other safe location where you can safely and legally obtain speeds up to 65 MPH, while also being able to rapidly decelerate.
- Begin with a series of light decelerations to gradually build some heat in the brakes. Use an on-and-off the pedal technique by applying the brakes for 3-5 seconds and then allow them to fully release for a period roughly twice as long as the deceleration cycle. If you use a 5 count during the deceleration interval, use a 10 count during the release to allow the heat to sink into the pads and rotors.
- After several cycles of light stops to begin warming the brakes, proceed with a series of medium to firm deceleration stops to continue raising the temperature level in the brakes.
- Finish the bedding cycle with a series of 8-10 hard decelerations from 55-65 MPH down to 25 MPH while allowing a proportionate release and heat-sinking interval between each stop. The pads should now be providing positive and consistent response.
- If any amount of brake fade is observed during the bed-in cycle, immediately begin the cool down cycle.
- Drive at a moderate cruising speed, with the least amount of brake contact possible, until most of the heat has dissipated from the brakes. Avoid sitting stopped with the brake pedal depressed to hold the car in place during this time. Park the vehicle and allow the brakes to cool to ambient air temperature.

POST-BEDDING INSPECTION: After the bedding cycle, the rotors should exhibit a uniformly burnished finish across the entire contact face. Any surface irregularities that appear as smearing or splotching on the rotor faces can be an indication that the brakes were brought up to temperature too quickly during the bedding cycle. If the smear doesn't blend away after the next run-in cycle, or if chatter under braking results, sanding or resurfacing the rotors will be required to restore a uniform surface for pad contact.

For any questions or suggestions please [CONTACT US](#)

