



LSMFG – GM CK10 14" Rear Brake Kit (with Parking Brake)



Fitment

71-87 Chevrolet CK10 Pickup
71-87 GMC CK15 Pickup
71-91 Chevrolet Blazer, Suburban, Vans
71-91 GMC Jimmy, Suburban, Vans

Even if your model is listed above, if it does not have the flange shown here, then the kit will not fit.

Note: The flange can be measured easily from the back side of the drum, without removing anything.

GM C10/K10

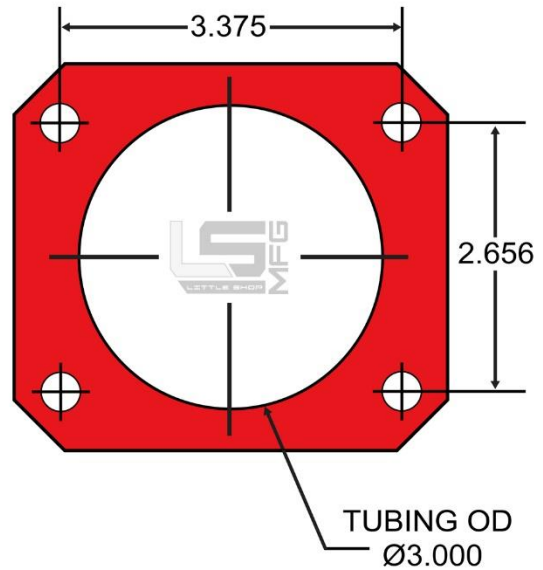

- Our 14" CK10 kit utilizes Wilwood 4-piston FNSL calipers, machined aluminum hats, and radial brackets which bolt directly to the factory axle housing flange without drilling. Designed to fit 71-87 (and some models to '91) full size 2wd and 4wd GM trucks and SUVs.
- It is the buyer's responsibility to check proper clearance and function of all brake parts to their existing suspension components and wheels/tires before driving the vehicle.

OE Hub Offset: Increase/Decrease Track Width	+ -.0
Caliper Type:	FNSL 4-Piston
Rotor Diameter:	14"
Min. Wheel Diameter:	18"

Warning

- Disc brakes should only be installed by someone experienced and competent in the installation and maintenance of disc brakes.
- If you are not sure of how to safely use this brake component or kit, you should not install or use it.
- Do not assume anything. Improperly installed or maintained brakes are dangerous. If you are not sure, get help or return the product.

Notes

- As with most suspension and tire modifications (from OEM specifications), changing the brakes may alter the front to rear brake bias. Your specific needs will depend on other modifications to the system.
- This kit can be operated using the stock OEM master cylinder.
- For added user control, the factory proportioning valve can be swapped to an adjustable proportioning valve such as [Wilwood 260-10922](#) or [Wilwood 260-11179](#). Installation of a Wilwood adjustable proportioning valve will require brake line work on your end to install since it is not a direct swap.
- The calipers can be connected to 3/16 brake lines with use of our [BRAKE LINE ADAPTERS](#) if you did not add our braided hoses. If you plan to make your own hardlines to the calipers, it is not necessary to use flexible hoses to the brake calipers since they are a fixed mount design (not floating).
- The brackets in this kit require the removal of the differential cover, cross pin, and C-clip retainers. This should be done per the OEM recommendations.
- This kit fits most 18-inch and larger diameter wheels.
- Use of Loctite® 271 to all threaded bolts is recommended.
- The included rotor hats measure .188 thickness whereas the factory drum measures .125 thickness. Technically, the difference moves the wheel outboard by .063 (or 1/16”), although that amount is typically insignificant.
- It is the responsibility of the buyer and installer of this kit to verify suitability/fitment of all components and ensure all fasteners and hardware achieve complete and proper engagement. Improper or inadequate engagement can lead to component failure.
- The images shown below are of a 2wd (C10) model, but the same installation steps apply to 4wd (K10) model.
- For any questions or suggestions, email: info@littleshopmfg.com

1 & 2



This installation refers to the **passenger side** of the axle. All steps are to be repeated on the driver side. Start by removing the factory drum. It may be necessary use a lubricant around the axle register to do this. Once the drum is removed, remove the brake shoe retaining springs (2 places) as shown.

3 & 4

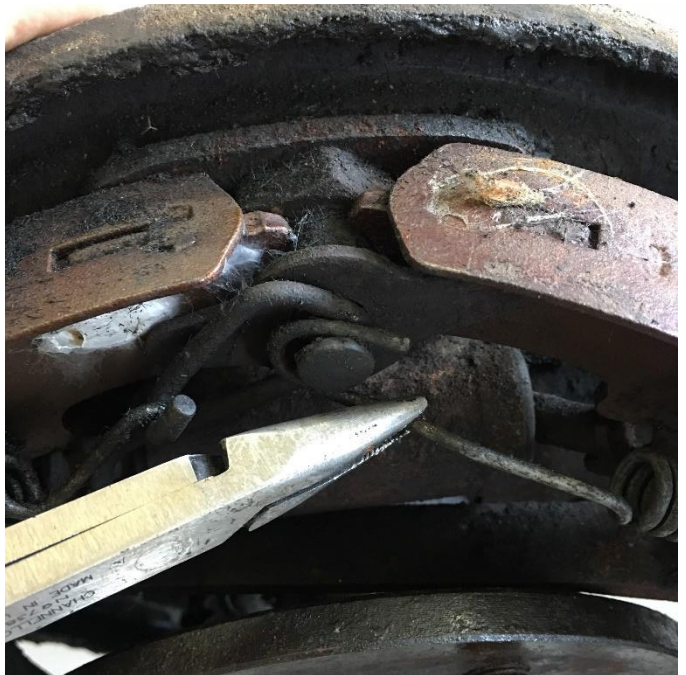

Remove the additional retaining springs from the brake shoes.



Disconnect the parking brake cable from the brake shoe, then remove and discard the brake shoes and hardware. The cable can then be removed from the backing plate by depressing its perimeter springs.



The axles will need to be removed from the housing by draining the fluid, then removing the differential cover, cross pin, and C-clip retainers. The 4 bolts retaining the drum backing plate to the axle can now be removed and discarded.



When using the stock parking brake cables, you will need to disassemble the parking brake assembly to install a new cable bracket. Your new levers are included separately. If you purchased our [Parking Brake Cable Kit](#), steps 9-17 are **NOT** required. To swap them out, start by removing the retention springs as shown.



Remove the tensioner and the remaining springs from the assembly so that you have access to the backing plate.



The existing bracket (shown in hand) can now be swapped for the new bracket (shown mounted in the assembly) which will attach to the factory cable.



After installing the new bracket, you can now begin reassembly of the brake shoes. Start by installing the inside top retaining spring and assemble the shoes onto the backing plate. Then insert the tensioner and then install the outside top spring.

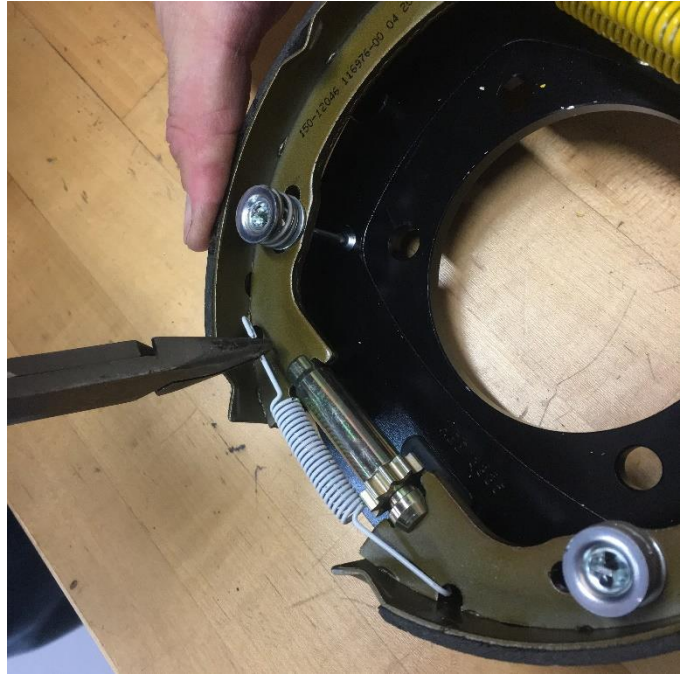

Reinstall the shoe retaining springs as shown, and then finish by reinstalling the bottom spring over the adjuster. At this time, the adjuster should be in the innermost position but not be bottomed out and difficult to adjust through the slotted window after assembly.

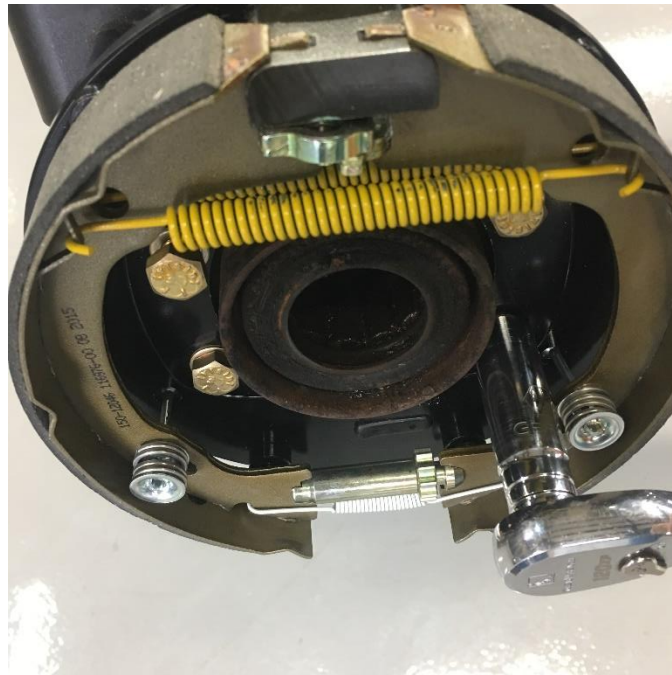

The parking brake assembly can now be installed onto the axle with the supplied hardware. **If the kit was optioned with braided hoses, you can position the brake line bracket on the bottom 2 holes of the flange with the tab facing the front side of the axle (NOT pictured).** The axle shaft can now be reinstalled per OEM recommendations.



The socket head screw and washers should be assembled as shown above starting with the screw, 3 washers, the bracket, 1 .625x.313x.015 shim washer, then the bracket spacer. You'll do this in 3 places. You can now bolt the caliper bracket to the emergency brake assembly and snug the bolts down. (You will not use threadlocker at this time) **NOTE: The end of the screw should not exceed the insert and interfere with the brake shoe.**



Arrange the rotor and hat in the position shown ensuring the arrow noting rotation direction is correct for its position on the vehicle. Start the first few threads of all 12 of the 1/4-20 x .75 12-point bolts. Using an alternating sequence, apply red Loctite® 271 to the threads, and torque to **155 in-lbs**. The rotor can now be installed using 2 lug nuts to temporarily secure it. Make sure that there is no drag from the parking brake shoes on the rotor at this time.

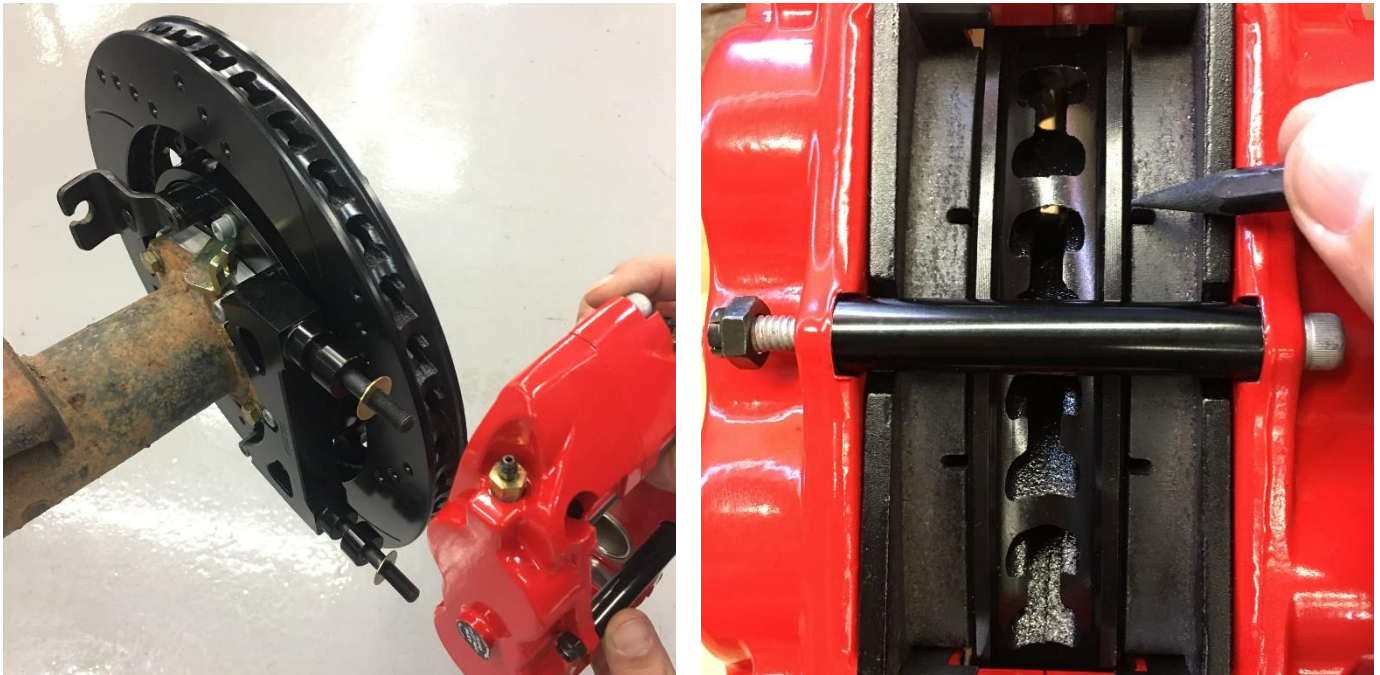

Lubricate the caliper mounting studs with lightweight oil. Initially place one .875x.375x.035 shim on each stud of the bracket. Mount the caliper using lock nuts and washers and ensure that it fully seats on the bracket and does not contact the rotor.

Remove the bridge bolt, nut, and spacer tube and install the pads at this time. Temporarily tighten the lock nuts and view the rotor through the top opening of the caliper. The caliper will need to be centered on the rotor by adding or subtracting the .750x.438x.035 shims between the caliper bracket and the bracket spacer. Always use the same amount of shims on each of the three mounting bolts.

Once the caliper alignment is correct side to side, check that the top of the brake pads are flush with the outside diameter of the rotor. For 14" rotors, the centers of the pads will be flush with the outside diameter of the rotor whereas the top and bottom of the pads will sit slightly under the diameter of the rotor. You can adjust the mounting height by adding or subtracting .875x.375x.035 shims between the caliper and the bracket.

After the caliper pad height is set, check that there is no pre-applied pressure when spinning the rotor. If so, make adjustments as necessary. Next, remove the bracket mounting bolts one at a time, apply red Loctite® 271 to the threads, reinstall, and torque them to **180 inch-lbs**. Torque the caliper lock nuts to **28 ft-lbs**. Then secure the brake pads in place with the center bridge pad retainer tube, bolt, and locknut. The locknut should be snug without play in the bolt or tube. However, be cautious not to over tighten.

Temporarily install the wheel and tighten the lug nuts. Ensure that the wheel rotates freely without any interference or contact to the caliper.



These Wilwood calipers utilize a 1/8 NPT fitting. **Do not thread any OEM tube-nuts into the caliper directly without adapting to 1/8 NPT.** This brake kit is available with an optional hose kit, which can also be purchased separately [HERE](#). Follow **steps 25-28** for installing the hose kit, otherwise it will be necessary to adapt from the 1/8 NPT fitting at the caliper to the fittings and hoses of your choice. Apply a small amount of sealant such as Loctite® 545 to the adapter fitting before installing the adapter into the caliper.

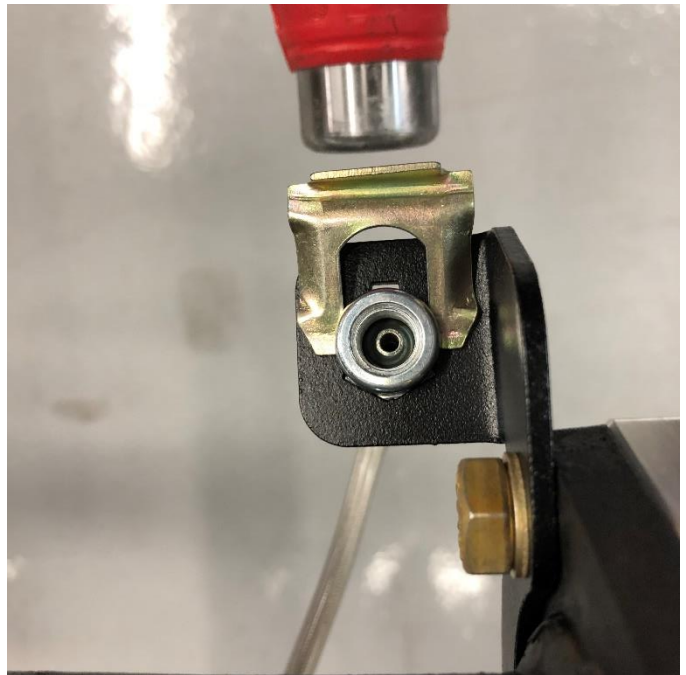
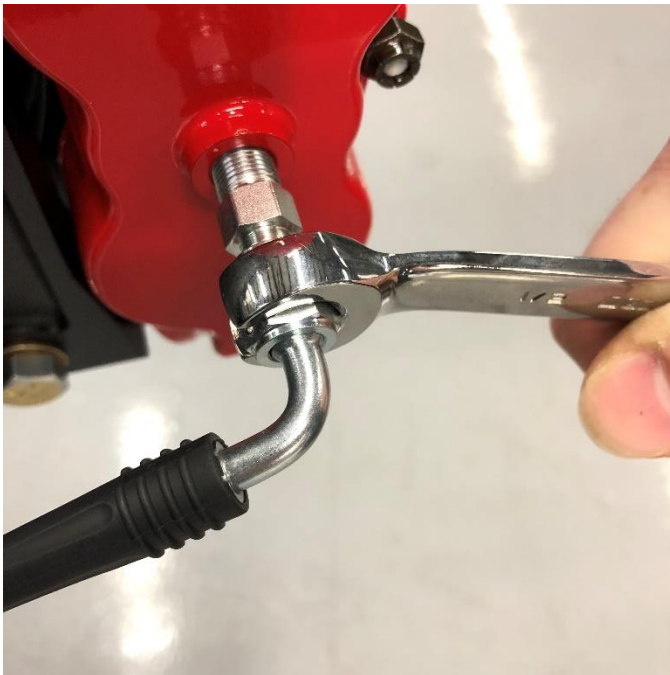

Install the stainless hose onto the caliper fitting. The hose will be routed under the axle and through the hose bracket. Install the retaining clip as shown, being careful not to bend the hose bracket. The factory brake hardline can then be rerouted into the top side of your brake line bracket and tightened into the braided hose.



Adjust the parking brake shoes outward using a drum shoe adjustment tool (available at your local parts store) or a flat head screwdriver. You'll do this by spinning the rotor slowly until a slight drag is felt against the hat/drum. The rotor will need lug nuts installed while doing this so that it remains fully seated against the axle shaft.



Install the stock parking brake cable into the bracket to hold cable in place. Mark the cable and spring to be cut beyond the cable stop by 1". Use a cut off wheel or cable cutters to cut the cable to the desired length.

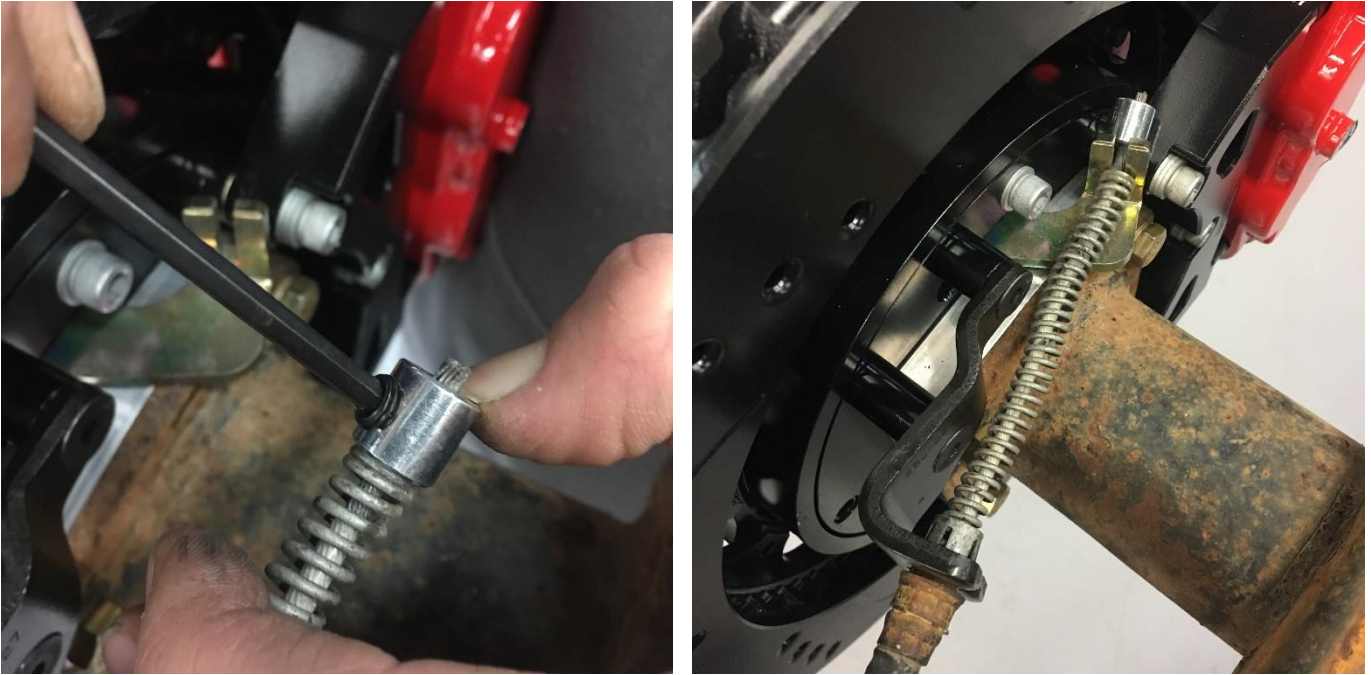

The supplied cable stops can be slid over the end of the cable and tightened down. It is suggested that you tighten the set screws and adjust the system for proper function at this time. There are typically points of adjustment on the factory cables along the chassis (depending on the model and cab configuration). The cable stop itself can be moved forward or backward depending on the needs of the system as well. Once the parking brake system is working correctly, the excess cable can be trimmed closer to the stop if desired.

Note: After properly bleeding your brake system, test the system per the “Brake Testing” procedure stated within this document before driving. After road testing, inspect for leaks and interference. Initially after install and testing, perform frequent checks of the vehicle brake system and lines before driving to confirm that there is no undue wear or interference not apparent from the initial test. Afterwards, perform periodic inspections for function, leaks and wear in an interval relative to the usage of vehicle.

Additional Information and Recommendations

- As with most suspension and tire modifications (from OEM specifications), changing the brakes may alter the front to rear brake bias. Rear brakes should not lock up before the front. Brake system evaluation and tests should be performed by persons experienced in the installation and proper operation of brake systems. Evaluation and tests should be performed under controlled conditions. Start by making several stops from low speeds then gradually work up to higher speeds. Always utilize safety restraint systems while operating the vehicle.
- For optimum performance, fill and bleed the new system with Wilwood Hi-Temp[°] 570 grade fluid or EXP 600 Plus. For severe braking or sustained high heat operation, use Wilwood EXP 600 Plus Racing Brake Fluid. Used fluid must be completely flushed from the system to prevent contamination. **Note:** Silicone DOT 5 brake fluid is **NOT** recommended for racing or performance driving.
- To properly bleed the brake system, begin with the caliper farthest from the master cylinder. Bleed the outboard bleed screw first, then the inboard. Repeat the procedure until all calipers in the system are bled, ending with the caliper closest to the master cylinder. If the caliper is fitted with bleed screws on four corners, make sure the bottom bleed screws are tight. Only bleed from the top bleed screws. **Note:** When using a new master cylinder, it is important to bench bleed the master cylinder first.
- Test the brake pedal. It should be firm, not spongy, and stop at least 1 inch from the floor under heavy load. If the brake pedal is spongy, bleed the system again. If the brake pedal is initially firm, but then sinks to the floor, check the system for leaks. Correct the leaks (if applicable) and then bleed the system again. If the brake pedal goes to the floor and continued bleeding of the system does not correct the problem, air may be trapped in the system.

Brake Testing

- Make sure your pedal is firm: Hold firm pressure on pedal for several minutes, it should remain in position without sinking. If pedal sinks toward floor, check system for fluid leaks. **DO NOT** drive the vehicle if pedal does not stay firm or can be pushed to the floor with normal pressure.
- At a very low speed (2-5 mph) apply brakes hard several times while turning steering from full left to full right, repeat several times. Remove the wheels and check that components are not touching, rubbing, or leaking.
- Carefully examine all brake components, brake lines, and fittings for leaks and interference. Make sure there is no interference with wheels or suspension components.
- Drive the vehicle at a low speed (15-20 mph) making moderate and hard stops. Brakes should feel normal and positive. Again, check for leaks and interference.
- Always test vehicle in a safe place where there is no danger to (or from) other people or vehicles.
- Always wear seat belts and make use of all safety equipment.

Pad and Rotor Bedding

- Once the brake system has been tested and determined safe to operate the vehicle, follow these steps for the bedding of the pads and rotors. These procedures should only be performed on a racetrack, or other safe location where you can safely and legally obtain speeds up to 65 MPH, while also being able to rapidly decelerate.
- Begin with a series of light decelerations to gradually build some heat in the brakes. Use an on-and-off the pedal technique by applying the brakes for 3-5 seconds, and then allow them to fully release for a period roughly twice as long as the deceleration cycle. If you use a 5-count during the deceleration interval, use a 10-count during the release to allow the heat to sink into the pads and rotors.
- After several cycles of light stops to begin warming the brakes, proceed with a series of medium to firm deceleration stops to continue raising the temperature level in the brakes.
- Finish the bedding cycle with a series of 8-10 hard decelerations from 55-65 MPH down to 25 MPH while allowing a proportionate release and heat-sinking interval between each stop. The pads should now be providing positive and consistent response.
- If any amount of brake fade is observed during the bed-in cycle, immediately begin the cool down cycle.
- Drive at a moderate cruising speed, with the least amount of brake contact possible, until most of the heat has dissipated from the brakes. Avoid sitting stopped with the brake pedal depressed to hold the car in place during this time. Park the vehicle and allow the brakes to cool to ambient air temperature.

COMPETITION VEHICLES: If your race car is equipped with brake cooling ducts, blocking them will allow the pads and rotors to warm up quicker and speed up the bedding process. Temperature indicating paint on the rotor and pad edges can provide valuable data regarding observed temperatures during the bedding process and subsequent on-track sessions. This information can be highly beneficial when evaluating pad compounds and cooling efficiencies.

POST-BEDDING INSPECTION: After the bedding cycle, the rotors should exhibit a uniformly burnished finish across the entire contact face. Any surface irregularities that appear as smearing or splotching on the rotor faces can be an indication that the brakes were brought up to temperature too quickly during the bedding cycle. If the smear doesn't blend away after the next run-in cycle, or if chatter under braking results, sanding or resurfacing the rotors will be required to restore a uniform surface for pad contact.

For any questions or suggestions, email: info@littleshopmfg.com

